

SINGLE LEVER BATH/SHOWER MIXER SET WITH 3 OUTLETS AND CYLINDRICAL HAND SHOWER









formma.

GR.01.3.21.XX

GR.01.4.05.XX (Single lever)



AVAILABLE FINISHES

-  **CR** | Chrome
-  **IE** | Brushed stainless steel
-  **BL** | Black
-  **WH** | White
-  **BB** | Brushed Black *PVD
-  **BR** | Brushed Bronze *PVD
-  **BC** | Brushed Copper *PVD
-  **BG** | Brushed gun metal *PVD
-  **BW** | Brushed white gold *PVD

TECHNICAL DRAWING (MEASUREMENT IN MM)

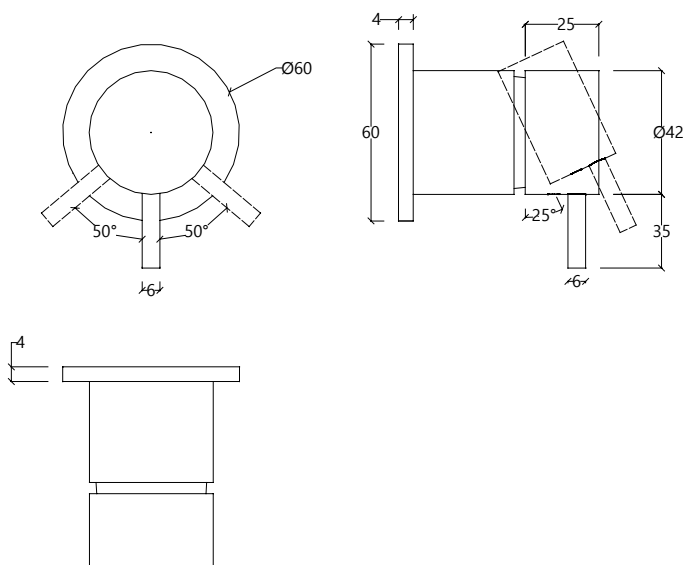

INSTALLATION RECOMENDATIONS

Before installing a tap, it is good to rinse the supply pipes to remove all residues. We also recommend installing the taps with a filter. The installation of the tap must be done with the surface clean and dry. To perform the water pressure test, the taps must be open.

CLEANING AND MAINTENANCE

Cleaning must be done with liquid soap and water. Do not use liquid detergents containing abrasive or acidic substances, abrasive sponges or disinfectants. Incorrect cleaning may permanently ruin the surface of taps. On color finishings, do not use products containing alcohol, acetone and other solvents.

WARRANTY

Formma guarantees all its products in case of manufacturing defects, as follows:

- 5-year warranty:
 - Fusion or porosity defects;
 - Cartridge defects (the wear of this component depends on water quality);
 - Chrome plating defects (defects caused by maintenance errors are excluded, please refer to cleaning instructions).
- 1-year warranty:
 - O-rings or fittings defects.
 - Defects on remaining finishes.

In order to use this warranty, please keep the invoice and attach it to this document.

Warranty grants the right of free replacement of parts that cause an irregular operation due to manufacturing defects, in every cases in which malfunction is not caused by incorrect use, maintenance errors, irregular installation, assembly made by unqualified people or reasons of force majeure.

Defective products must be sent to formma, with shipping expenses borne by the sender – this warranty document and a copy of the purchase invoice must be attached to the package – where the products will be promptly replaced and send back with shipping expenses borne by formma.

Non-compliance of this conditions will render the warranty null and void. This warranty excludes any liabilities on the consequences arising from use or installation defects of formma products.

COMPONENT DRAWING

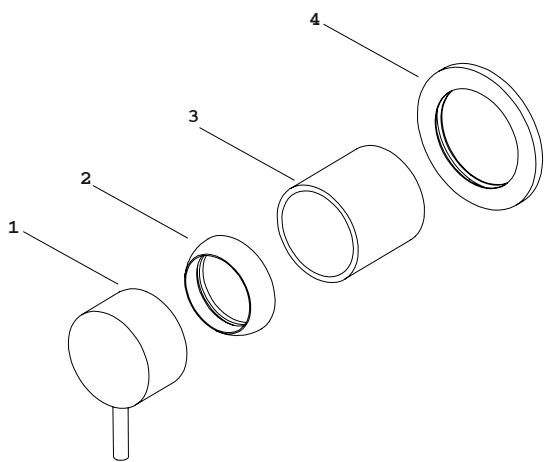

TECHNICAL DATA

n°	DESCRIPTION
01	HANDLE
02	CARTRIDGE CONCEALER
03	HOOD
04	HANDLE PLATE

SINGLE LEVER BATH/SHOWER MIXER SET WITH 3 OUTLETS AND CYLINDRICAL HAND SHOWER









formma.

GR.01.3.21.XX

GR.01.4.21.XX (Single lever)



AVAILABLE FINISHES

-  **CR** | Chrome
-  **IE** | Brushed stainless steel
-  **BL** | Black
-  **WH** | White
-  **BB** | Brushed Black *PVD
-  **BR** | Brushed Bronze *PVD
-  **BC** | Brushed Copper *PVD
-  **BG** | Brushed gun metal *PVD
-  **BW** | Brushed white gold *PVD

TECHNICAL DRAWING (MEASUREMENT IN MM)

Front View

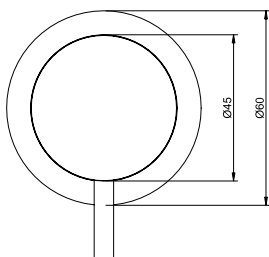

Side View

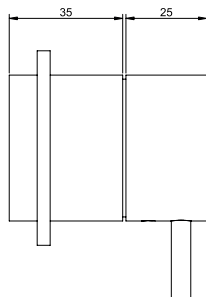

Top View

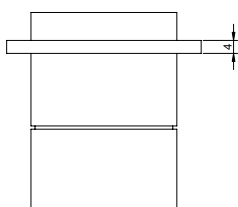

RECOMENDATIONS

The installation must be made by specialized technicians that have to consider the instructions contained on the product. The components of the product cannot be altered or modified, otherwise the warranty will be annulled. The recommended pressure and temperature must be strictly followed. If they are exceeded or reduced, it can cause permanent damages to the tap.

MAINTENANCE

We recommend regular maintenance of the tap in order to assure the permanent good function of it. To clean the tap, please use a smooth cloth with water and neutral soap. Never use products with abrasives substances such as chloride acid, ammonia, acetone, vinegar, bleach or abrasive sponges. The usage of non-recommended products might damage permanently the surfaces which will annul the warranty.

WARRANTY

Formma guarantees all its products in case of manufacturing defects, as follows:

5 Year warranty :

- Machining or casting faults and porosity defects;
 - Cartridge and valve defects (the wear of this component depends on water quality);
 - Chrome plating or PVD defects. Defects caused by improper use are excluded, please refer to the maintenance instructions.
- 2 Year warranty :

Powder Coating finishes. Defects caused by improper use are excluded, please refer to the maintenance instructions. Our responsibility is exclusively subject to defects originated on the production process.

The warranty does not cover components subject to wear and tear, such as O-rings, gaskets, flexible hoses and joints for connections.

Attention :

Natural finishes, such as brass or stainless steel, depend entirely on the exposure to the environment and maintenance. Therefore, any stain that may appear cannot be considered a product defect.

COMPONENT DRAWING

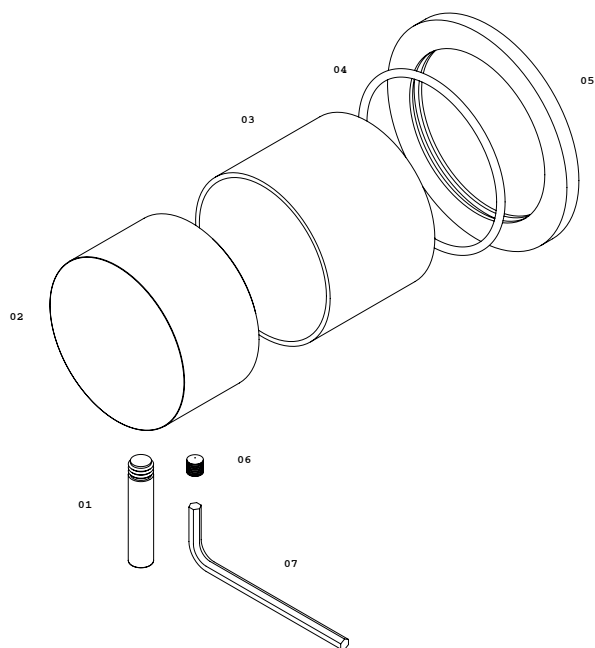

The warranty gives the customer the right to have all the parts replaced, free of charge, if they are not working properly, due to manufacturing fault.

The following are excluded from the warranty:

- Items or parts which are damaged or do not work properly due to negligence in the use or wrong maintenance;
- Wrong installation;

- Intervention by unqualified people or circumstances beyond one's control.

In order to use this warranty, please keep the invoice and attach it to this document. Defective products must be sent to Formma with shipping expenses borne by the sender. This warranty document and a copy of the purchase invoice must be attached to the package. The products will be promptly replaced and sent back with shipping expenses borne by formma.

TECHNICAL DATA

n°	DESCRIPTION
01	ROD
02	HANDLE
03	COVER
04	ORING
05	PLATE
06	ALLEN SCREW
07	ALLEN KEY

SINGLE LEVER BATH/SHOWER MIXER SET WITH 3 OUTLETS AND CYLINDRICAL HAND SHOWER









formma.

GR.01.3.21.XX

GR.01.7.03.XX (Single lever)



AVAILABLE FINISHES

-  **CR** | Chrome
-  **IE** | Brushed stainless steel
-  **BL** | Black
-  **WH** | White
-  **BB** | Brushed Black *PVD
-  **BR** | Brushed Bronze *PVD
-  **BC** | Brushed Copper *PVD
-  **BG** | Brushed gun metal *PVD
-  **BW** | Brushed white gold *PVD

TECHNICAL DRAWING (MEASUREMENT IN MM)

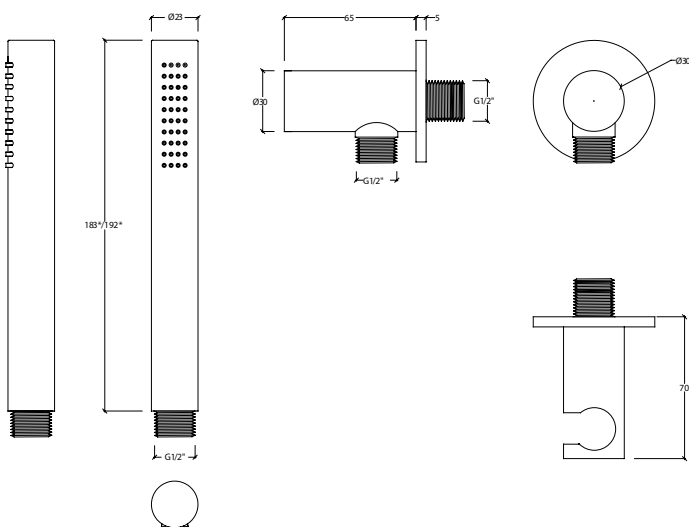

RECOMENDATIONS

The installation must be made by specialized technicians that have to consider the instructions contained on the product. The components of the product cannot be altered or modified, otherwise the warranty will be annulled. The recommended pressure and temperature must be strictly followed. If they are exceeded or reduced, it can cause permanent damages to the tap.

MAINTENANCE

We recommend regular maintenance of the tap in order to assure the permanent good function of it. To clean the tap, please use a smooth cloth with water and neutral soap. Never use products with abrasives substances such as chloride acid, ammonia, acetone, vinegar, bleach or abrasive sponges. The usage of non-recommended products might damage permanently the surfaces which will annul the warranty.

WARRANTY

Formma guarantees all its products in case of manufacturing defects, as follows:

5 Year warranty :

- Machining or casting faults and porosity defects;
 - Cartridge and valve defects (the wear of this component depends on water quality);
 - Chrome plating or PVD defects. Defects caused by improper use are excluded, please refer to the maintenance instructions.
- 2 Year warranty :

Powder Coating finishes. Defects caused by improper use are excluded, please refer to the maintenance instructions.

Our responsibility is exclusively subject to defects originated on the production process.

The warranty does not cover components subject to wear and tear, such as O-rings, gaskets, flexible hoses and joints for connections.

Attention :

Natural finishes, such as brass or stainless steel, depend entirely on the exposure to the environment and maintenance. Therefore, any stain that may appear cannot be considered a product defect.

COMPONENT DRAWING

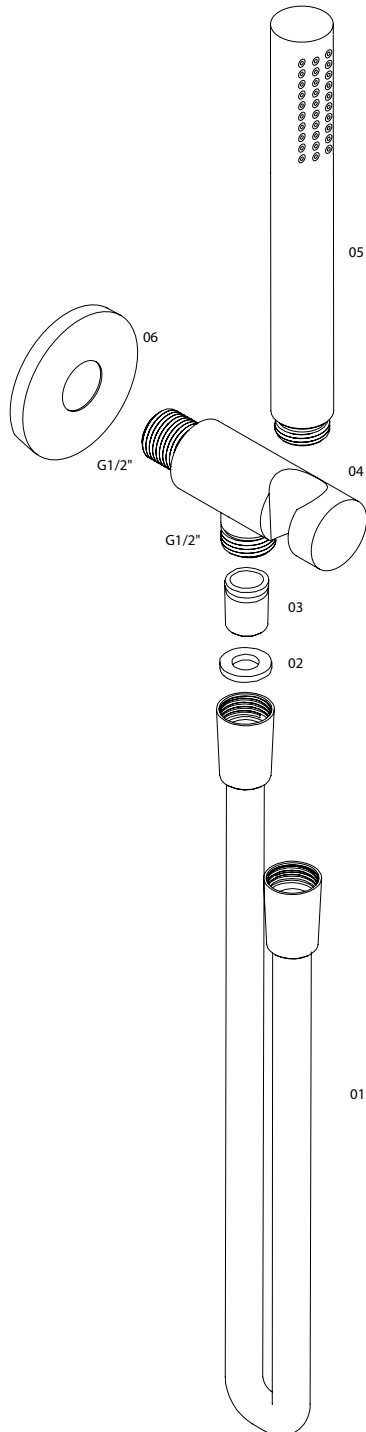

Attention :

Natural finishes, such as brass or stainless steel, depend entirely on the exposure to the environment and maintenance. Therefore, any stain that may appear cannot be considered a product defect. The warranty gives the customer the right to have all the parts replaced, free of charge, if they are not working properly, due to manufacturing fault.

The following are excluded from the warranty:

- Items or parts which are damaged or do not work properly due to negligence in the use or wrong maintenance;
- Wrong installation;
- Intervention by unqualified people or circumstances beyond one's control.

In order to use this warranty, please keep the invoice and attach it to this document. Defective products must be sent to Formma with shipping expenses borne by the sender. This warranty document and a copy of the purchase invoice must be attached to the package. The products will be promptly replaced and sent back with shipping expenses borne by Formma.

TECHNICAL DATA

n°	DESCRIPTION
01	FLEXIBLE
02	SEALING WASHER
03	CHECK VALVE
04	SHOWER HOLDER
05	HAND SHOWER
06	PLATE

MINIMUM PRESSURE	1 BAR
MAXIMUM PRESSURE	10 BAR
RECOMMENDED PRESSURE	2-5 BAR
MAXIMUM TEMPERATURE	70° / 176 F
RECOMMENDED TEMPERATURE	65° / 149 F
CAUDAL	12 L /min - 3 BAR

ASSEMBLY INSTRUCTIONS

IMAGE 1

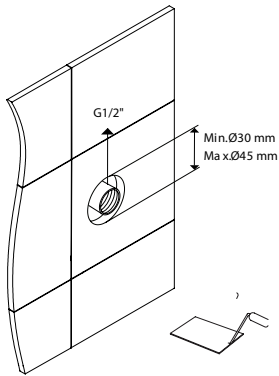

01 - Drill the hole on the coating, for the shower holder.

Hole diameter: Min. 30 mm. / Max. 45 mm.

02 - After completing step 1, proceed with the application of the coating.

IMAGE 2

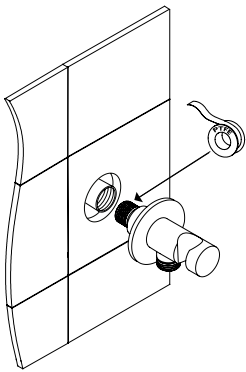
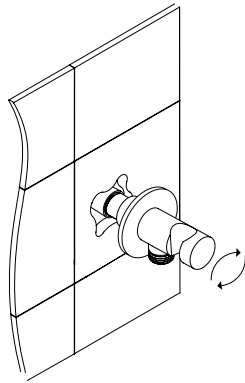

IMAGE 3



01 - You must properly isolate the G 1/2 "thread from the shower inlet, with Teflon (PTFE) or something compatible for that purpose. This sealing must be done carefully, so that there is no water leakage. Confirm before completing this procedure that the sealing is guaranteed.

01 - After sealing the water inlet, proceed with tightening the shower holder, ensuring its verticality.

IMAGE 4

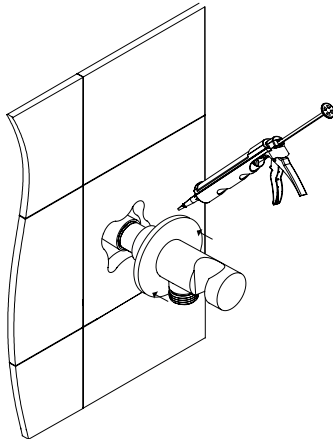

01 - After tightening the shower holder, apply silicone on the back of the plate and fit it to the coating.

IMAGE 5

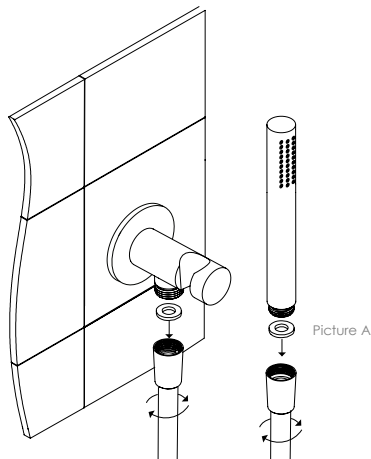

01 - Certify the sealing washers are in the correct position (picture A).

02 - Proceed to tighten the hose to the water shower outlet.

03 - Then tighten the hand shower to the hose.

End of installation

SINGLE LEVER BATH/SOWER MIXER SET WITH 3 OUTLETS AND CYLINDRICAL HAND SHOWER

formma.

GR.01.3.21.XX

GR.01.0.12 (Single lever)

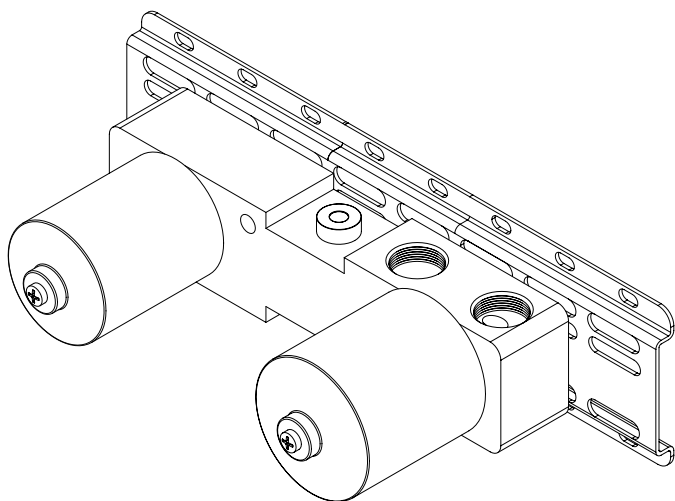

TECHNICAL DATA

MINIMUM PRESSURE	1 BAR
MAXIMUM PRESSURE	10 BAR
RECOMMENDED PRESSURE	2-5 BAR
MAXIMUM TEMPERATURE	70° / 176 F
RECOMMENDED TEMPERATURE	65° / 149 F
BUILT-IN DEPTH PROFUNDIDADE	55 - 70 mm

TECHNICAL DRAWING (MEASUREMENTS IN MM)

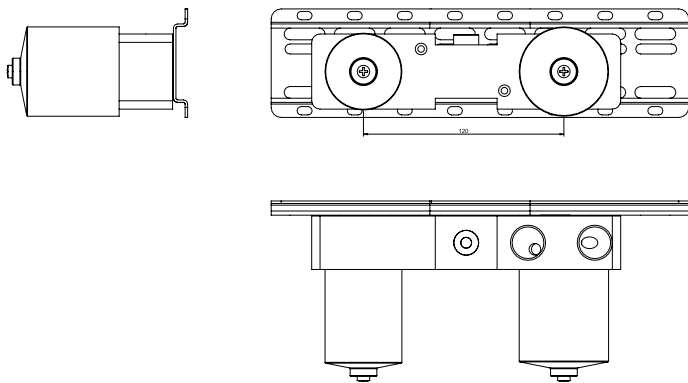

INSTALLATION RECOMMENDATIONS

The installation must be made by specialized technicians that have to consider the instructions contained on the product. The components of the product cannot be altered or modified, otherwise the warranty will be annulled. The recommended pressure and temperature must be strictly followed. If they are exceeded or reduced, it can cause permanent damages to the tap.

CLEANING AND MAINTENANCE

We recommend regular maintenance of the tap in order to assure the permanent good function of it. To clean the tap, please use a smooth cloth with water and neutral soap. Never use products with abrasives substances such as chloride acid, ammonia, acetone, vinegar, bleach or abrasive sponges. The usage of non-recommended products might damage permanently the surfaces which will annul the warranty.

WARRANTY

Formma guarantees all its products in case of manufacturing defects, as follows:

5 Year warranty:

- Machining or casting faults and porosity defects;
- Cartridge and valve defects (the wear of this component depends on water quality);
- Chrome plating or PVD defects. Defects caused by improper use are excluded, please refer to the maintenance instructions.;

2 Year warranty:

- Powder Coating finishes. Defects caused by improper use are excluded, please refer to the maintenance instructions.

Our responsibility is exclusively subject to defects originated on the production process.

The warranty does not cover components subject to wear and tear, such as O-rings, gaskets, flexible hoses and joints for connections.

COMPONENT DRAWING

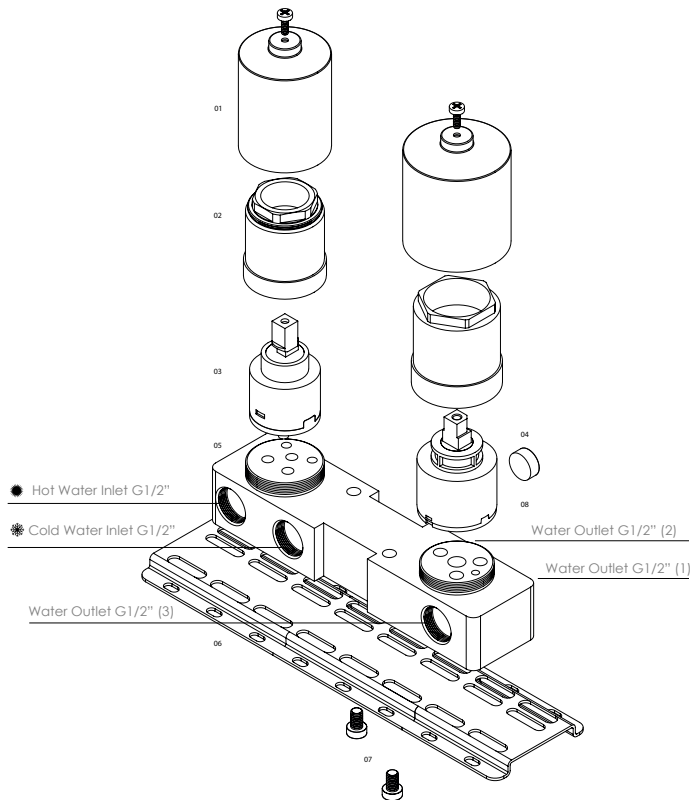

Attention :

Natural finishes, such as brass or stainless steel, depend entirely on the exposure to the environment and maintenance. Therefore, any stain that may appear cannot be considered a product defect. The warranty gives the customer the right to have all the parts replaced, free of charge, if they are not working properly, due to manufacturing fault.

The following are excluded from the warranty:

- Items or parts which are damaged or do not work properly due to negligence in the use or wrong maintenance;
- Wrong installation;
- Intervention by unqualified people or circumstances beyond one's control.

In order to use this warranty, please keep the invoice and attach it to this document. Defective products must be sent to Formma with shipping expenses borne by the sender. This warranty document and a copy of the purchase invoice must be attached to the package. The products will be promptly replaced and sent back with shipping expenses borne by Formma.

TECHNICAL DATA

n°	DESCRIPTION
01	PLASTIC COVER
02	LOCKING NUT COVER
03	CARTRIDGE MIXER
04	SPIRIT LEVEL
05	MIXER BODY
06	PLATE
07	SCREW
08	3 WAYS DIVERTER

ASSEMBLY INSTRUCTIONS

IMAGE 1

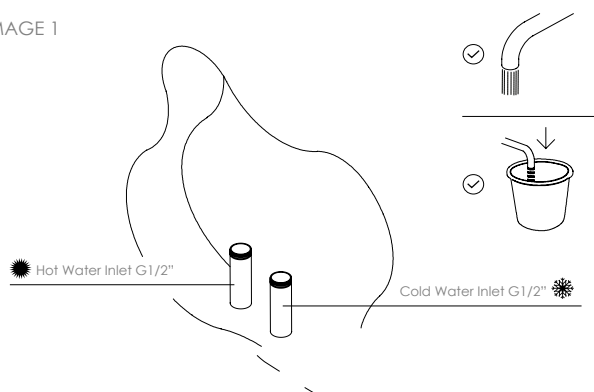

Attention! Before starting the installation, the pipes must be properly cleaned to eliminate any dirt that may cause permanent damages to the cartridge.

IMAGE 2

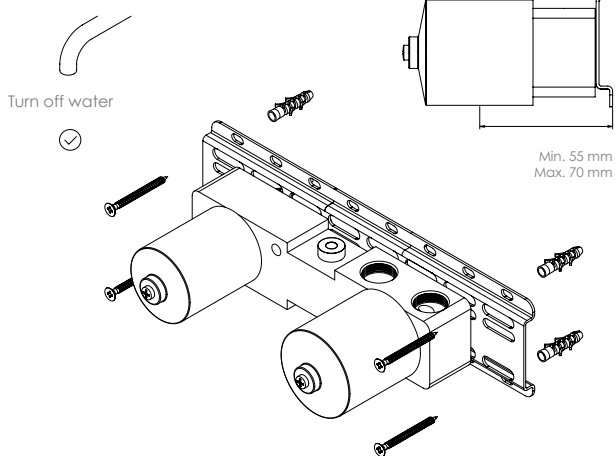

Ensure the water supply is turned off before proceeding to the mixer installation

01 - Verify on the picture "A" the maximum and minimum measurements for internal part installation.
Min. 55 mm / Max.70 mm

02 - Please mark the wall where the internal part GR.01.0.12 will be placed.

03 - After marking four fixation points, drill the wall.

04 - Screw the fixing plate with compatible bolts (not included), leaving them untight enough for the following step.

IMAGE 3

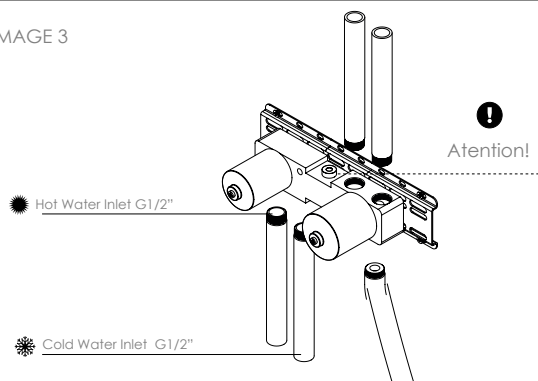

01 - Confirm on the spirit level (included on the mixer seat) that the piece is levelled with the floor. After ensuring the alignment is correct, conclude the tightening of the bolts.

02 - Proceed to the water connections, connecting cold and hot water to the corresponding tubes.

03 - Please guarantee that these connections are done correctly before placing the coating on the wall.

IMAGE 4

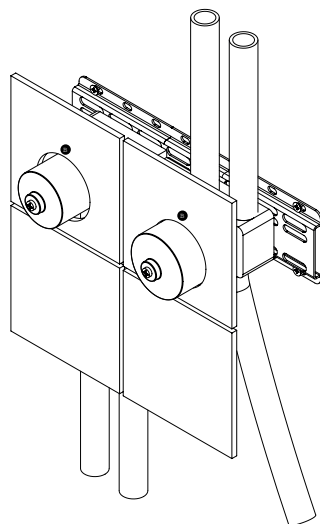

01 - Drill the holes on the coating, for the mixer (verify on the picture "B"). Mixer diameter: Max. 50 mm.

02 - After completing step 1, proceed with the application of the coating.