









# CONCEALED STOP VALVE - EXTERNAL PART WITH ROUND PLATE

formma.

GR.01.4.16.XX



## AVAILABLE FINISHES

-  **CR** | Chrome
-  **IE** | Brushed stainless steel
-  **BL** | Black
-  **WH** | White
-  **BB** | Brushed Black \*PVD
-  **BR** | Brushed Bronze \*PVD
-  **BC** | Brushed Copper \*PVD
-  **BG** | Brushed gun metal \*PVD
-  **BW** | Brushed white gold \*PVD

## TECHNICAL DRAWING (MEASUREMENT IN MM)

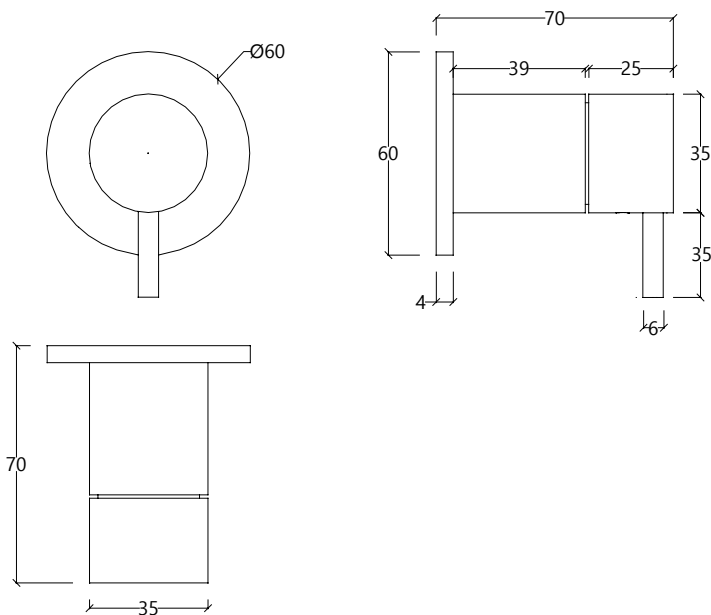

## RECOMENDATIONS

The installation must be made by specialized technicians that have to consider the instructions contained on the product. The components of the product cannot be altered or modified, otherwise the warranty will be annulled. The recommended pressure and temperature must be strictly followed. If they are exceeded or reduced, it can cause permanent damages to the tap.

## MAINTENANCE

We recommend regular maintenance of the tap in order to assure the permanent good function of it. To clean the tap, please use a smooth cloth with water and neutral soap. Never use products with abrasives substances such as chloride acid, ammonia, acetone, vinegar, bleach or abrasive sponges. The usage of non-recommended products might damage permanently the surfaces which will annul the warranty.

## WARRANTY

Formma guarantees all its products in case of manufacturing defects, as follows:

5 Year warranty :

- Machining or casting faults and porosity defects;
  - Cartridge and valve defects (the wear of this component depends on water quality);
  - Chrome plating or PVD defects. Defects caused by improper use are excluded, please refer to the maintenance instructions.
- 2 Year warranty :

Powder Coating finishes. Defects caused by improper use are excluded, please refer to the maintenance instructions.

Our responsibility is exclusively subject to defects originated on the production process.

The warranty does not cover components subject to wear and tear, such as O-rings, gaskets, flexible hoses and joints for connections.

Attention :

Natural finishes, such as brass or stainless steel, depend entirely on the exposure to the environment and maintenance. Therefore, any stain that may appear cannot be considered a product defect.

## COMPONENT DRAWING

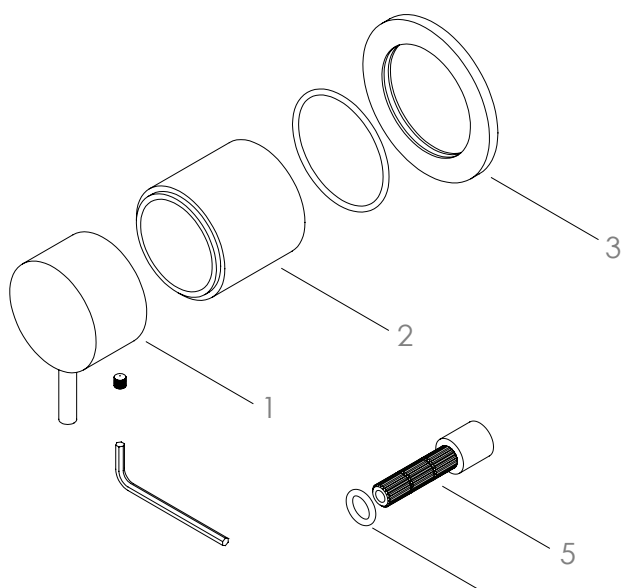

## TECHNICAL DATA

n°	DESCRIPTION
01	HANDLE
02	HOOD
03	PLATE
04	O-RING
05	EXTENSION