

# WALL-MOUNTED WASHBASIN MIXER SET WITH 21CM SPOUT

formma.

## GR.01.2.03.XX





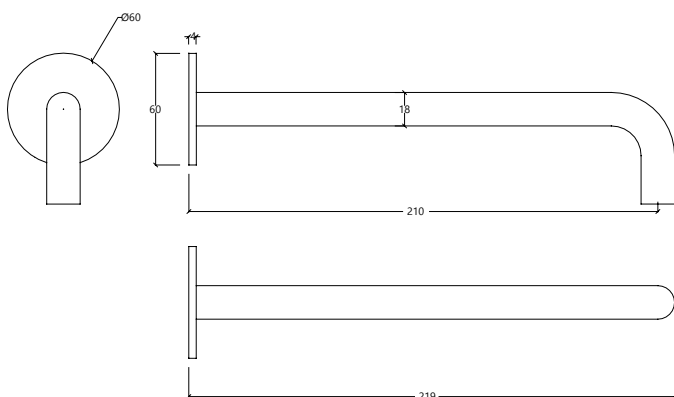

GR.01.5.14.XX (Spout)



### TECHNICAL DRAWING (MEASUREMENT IN MM)



### AVAILABLE FINISHES

-  CR | Chrome
-  BI | Brushed stainless steel
-  BL | Black
-  WH | White
-  BB | Brushed Black \*PVD
-  BR | Brushed Bronze \*PVD
-  BC | Brushed Copper \*PVD
-  BG | Brushed gun metal \*PVD
-  BW | Brushed white metal \*PVD

### INSTALLATION RECOMENDATIONS

Before installing a tap, it is good to rinse the supply pipes to remove all residues. We also recommend installing the taps with a filter. The installation of the tap must be done with the surface clean and dry. To perform the water pressure test, the taps must be open.

### CLEANING AND MAINTENANCE

Cleaning must be done with liquid soap and water. Do not use liquid detergents containing abrasive or acidic substances, abrasive sponges or disinfectants. Incorrect cleaning may permanently ruin the surface of taps. On color finishings, do not use products containing alcohol, acetone and other solvents.

### WARRANTY

Formma guarantees all its products in case of manufacturing defects, as follows:

- 5-year warranty:
  - Fusion or porosity defects;
  - Cartridge defects (the wear of this component depends on water quality);
  - Chrome plating defects (defects caused by maintenance errors are excluded, please refer to cleaning instructions).
- 1-year warranty:
  - O-rings or fittings defects.
  - Defects on remaining finishes.

In order to use this warranty, please keep the invoice and attach it to this document.

Warranty grants the right of free replacement of parts that cause an irregular operation due to manufacturing defects, in every cases in which malfunction is not caused by incorrect use, maintenance errors, irregular installation, assembly made by unqualified people or reasons of force majeure.

Defective products must be sent to formma, with shipping expenses borne by the sender – this warranty document and a copy of the purchase invoice must be attached to the package – where the products will be promptly replaced and send back with shipping expenses borne by formma.

Non-compliance of this conditions will render the warranty null and void. This warranty excludes any liabilities on the consequences arising from use or installation defects of formma products.

## COMPONENT DRAWING

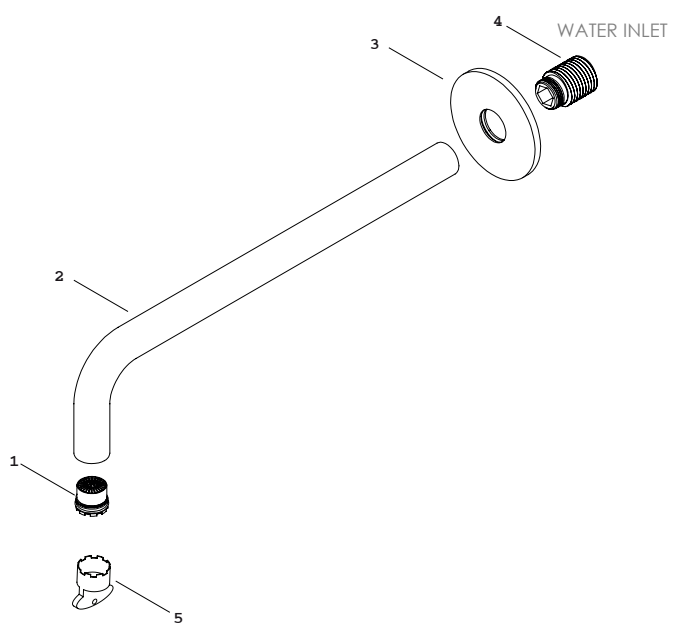

## TECHNICAL DATA

n°	DESCRIPTION
01	AERATOR
02	SPOUT
03	PLATE
04	CANNON
05	AERATOR KEYS

# WALL-MOUNTED WASHBASIN MIXER SET WITH 21CM SPOUT

formma.

## GR.01.2.03.XX







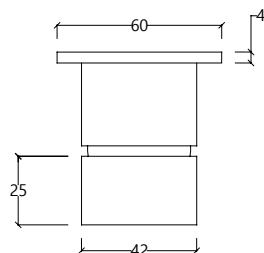
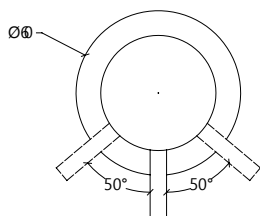
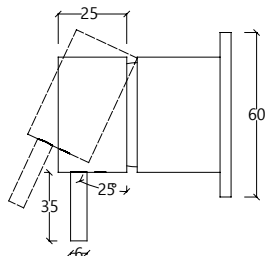

GR.01.4.03.XX (Single lever)



### TECHNICAL DRAWING (MEASUREMENT IN MM)



### AVAILABLE FINISHES

-  **CR** | Chrome
-  **BI** | Brushed stainless steel
-  **BL** | Black
-  **WH** | White
-  **BB** | Brushed Black \*PVD
-  **BR** | Brushed Bronze \*PVD
-  **BC** | Brushed Copper \*PVD
-  **BG** | Brushed gun metal \*PVD
-  **BW** | Brushed white gold \*PVD

### INSTALLATION RECOMENDATIONS

Before installing a tap, it is good to rinse the supply pipes to remove all residues. We also recommend installing the taps with a filter. The installation of the tap must be done with the surface clean and dry. To perform the water pressure test, the taps must be open.

### CLEANING AND MAINTENANCE

Cleaning must be done with liquid soap and water. Do not use liquid detergents containing abrasive or acidic substances, abrasive sponges or disinfectants. Incorrect cleaning may permanently ruin the surface of taps. On color finishings, do not use products containing alcohol, acetone and other solvents.

### WARRANTY

Formma guarantees all its products in case of manufacturing defects, as follows:

- 5-year warranty:
  - Fusion or porosity defects;
  - Cartridge defects (the wear of this component depends on water quality);
  - Chrome plating defects (defects caused by maintenance errors are excluded, please refer to cleaning instructions).
- 1-year warranty:
  - O-rings or fittings defects.
  - Defects on remaining finishes.

In order to use this warranty, please keep the invoice and attach it to this document.

Warranty grants the right of free replacement of parts that cause an irregular operation due to manufacturing defects, in every cases in which malfunction is not caused by incorrect use, maintenance errors, irregular installation, assembly made by unqualified people or reasons of force majeure.

Defective products must be sent to formma, with shipping expenses borne by the sender – this warranty document and a copy of the purchase invoice must be attached to the package – where the products will be promptly replaced and send back with shipping expenses borne by formma.

Non-compliance of this conditions will render the warranty null and void. This warranty excludes any liabilities on the consequences arising from use or installation defects of formma products.

## COMPONENT DRAWING

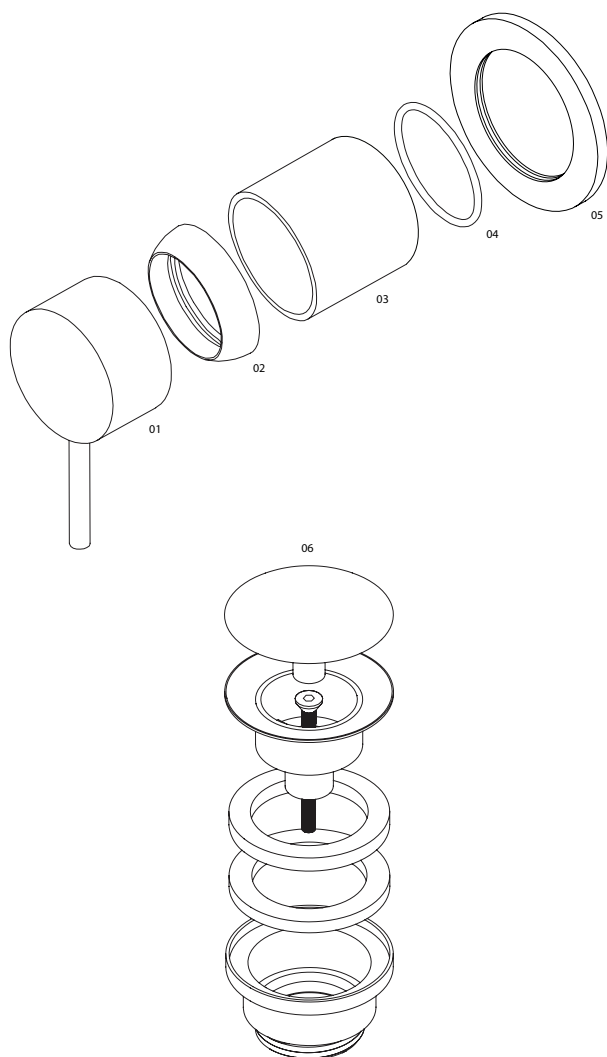

## Attention :

Natural finishes, such as brass or stainless steel, depend entirely on the exposure to the environment and maintenance. Therefore, any stain that may appear cannot be considered a product defect. The warranty gives the customer the right to have all the parts replaced, free of charge, if they are not working properly, due to manufacturing fault.

The following are excluded from the warranty:

- Items or parts which are damaged or do not work properly due to negligence in the use or wrong maintenance;
- Wrong installation;
- Intervention by unqualified people or circumstances beyond one's control.

In order to use this warranty, please keep the invoice and attach it to this document. Defective products must be sent to Formma with shipping expenses borne by the sender. This warranty document and a copy of the purchase invoice must be attached to the package. The products will be promptly replaced and sent back with shipping expenses borne by Formma.

## TECHNICAL DATA

n°	DESCRIPTION
01	HANDLE
02	CARTRIDGE CONCEALER
03	HOOD
04	O'RING MIXER PLATE
05	MIXER PLATE
06	CLICK CLACK WASTE VALVE

MINIMUM PRESSURE	1 BAR
MAXIMUM PRESSURE	10 BAR
RECOMMENDED PRESSURE	2-5 BAR
MAXIMUM TEMPERATURE	70° / 176 F
RECOMMENDED TEMPERATURE	65° / 149 F

ASSEMBLY INSTRUCTIONS

IMAGE 1

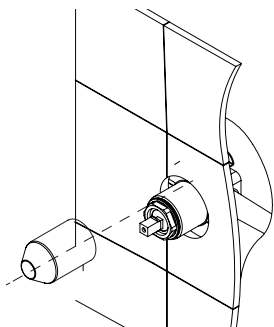

01 - After the coating is applied and file joints are filled in, please remove the plastic protection covering the mixer.

IMAGE 2

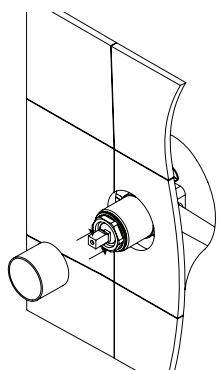

01 - Place the hood over the tecaform body.

IMAGE 3

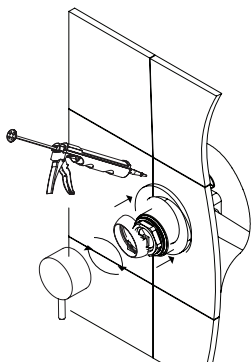

01 - Place the plate on the mixer body, apply silicone on the back of the plate and fit it to the coating.

02 - Dcrew the cartridge concealer to the locknut on the tecaform body.

03 - Place the handle onto the cartridge and verify if the rod is in a vertical position.

IMAGE 4

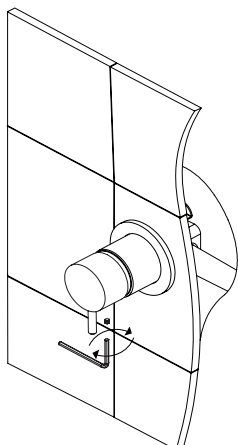

01 - Place the allen bolt inside the hole under the handle.

02 - Screw it with an allen key.

## CARTRIDGE REPLACEMENT

01



02

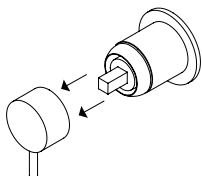

01 - Unscrew the handle with the help of the allen key.

02 - Remove the handle from the top of the cartridge.

03

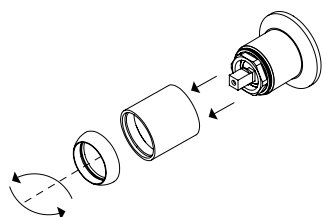

04

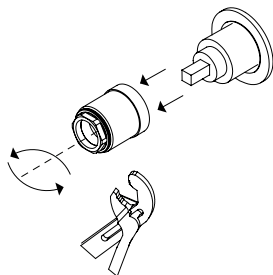

03 - Unscrew the cartridge concealer from the tecaform locknut, then remove the hood from the tecaform piece.

04 - Unscrew the tecaform locknut with the help of a wrench. After this, you can remove the cartridge.

Para instalar un cartucho nuevo, considere el procedimiento inverso.

# TWO-HOLE CONCEALED WASHBASIN MIXER (INTERNAL PART)

formma.

## GR.01.2.03.XX

GR.01.0.01 (Internal part)

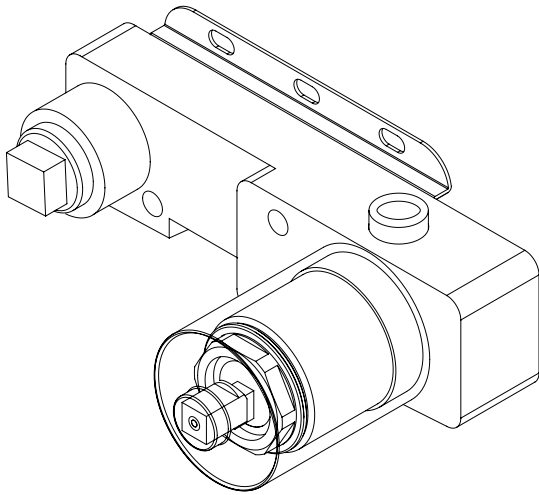

### TECHNICAL DATA

MINIMUM PRESSURE	1 BAR
MAXIMUM PRESSURE	10 BAR
RECOMMENDED PRESSURE	2-5 BAR
MAXIMUM TEMPERATURE	70° / 176 F
RECOMMENDED TEMPERATURE	65° / 149 F
FLOW RATE WITH AERATOR	5.6 l/min - 3 BAR

### TECHNICAL DRAWING (MEASUREMENTS IN MM)

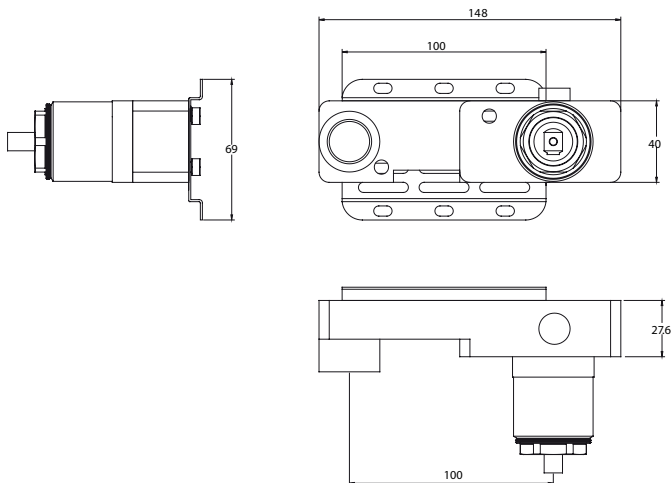

### INSTALLATION RECOMMENDATIONS

The installation must be made by specialized technicians that have to consider the instructions contained on the product. The components of the product cannot be altered or modified, otherwise the warranty will be annulled. The recommended pressure and temperature must be strictly followed. If they are exceeded or reduced, it can cause permanent damages to the tap.

### CLEANING AND MAINTENANCE

We recommend regular maintenance of the tap in order to assure the permanent good function of it. To clean the tap, please use a smooth cloth with water and neutral soap. Never use products with abrasives substances such as chloride acid, ammonia, acetone, vinegar, bleach or abrasive sponges. The usage of non-recommended products might damage permanently the surfaces which will annul the warranty.

### WARRANTY

Formma guarantees all its products in case of manufacturing defects, as follows:

5 Year warranty:

- Machining or casting faults and porosity defects;
- Cartridge and valve defects (the wear of this component depends on water quality);
- Chrome plating or PVD defects. Defects caused by improper use are excluded, please refer to the maintenance instructions.;

2 Year warranty:

- Powder Coating finishes. Defects caused by improper use are excluded, please refer to the maintenance instructions.

Our responsibility is exclusively subject to defects originated on the production process.

The warranty does not cover components subject to wear and tear, such as O-rings, gaskets, flexible hoses and joints for connections.

# GR.01.2.03.XX

GR.01.0.01 (Internal part)

## COMPONENT DRAWING

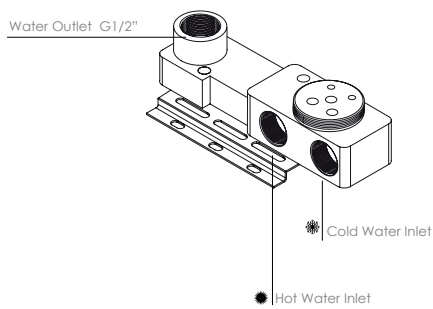
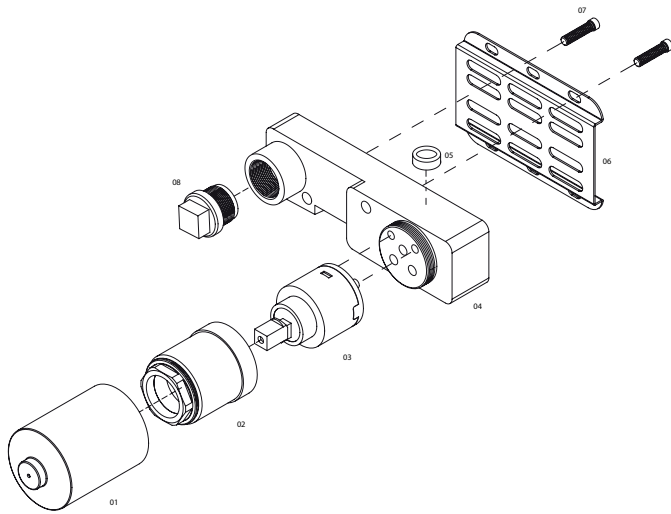

### Attention :

Natural finishes, such as brass or stainless steel, depend entirely on the exposure to the environment and maintenance. Therefore, any stain that may appear cannot be considered a product defect. The warranty gives the customer the right to have all the parts replaced, free of charge, if they are not working properly, due to manufacturing fault.

The following are excluded from the warranty:

- Items or parts which are damaged or do not work properly due to negligence in the use or wrong maintenance;
- Wrong installation;
- Intervention by unqualified people or circumstances beyond one's control.

In order to use this warranty, please keep the invoice and attach it to this document. Defective products must be sent to Formma with shipping expenses borne by the sender. This warranty document and

a copy of the purchase invoice must be attached to the package. The products will be promptly replaced and sent back with shipping expenses borne by Formma.

## TECHNICAL DATA

n°	DESCRIPTION
01	PLASTIC CUP
02	TECAFORM FASTENING NUT
03	35 MM CARTRIDGE
04	MONOBLOCK
05	SPIRIT LEVEL
06	FIXING PLATE
07	SCREW
08	HALF INCH CAP



# GR.01.2.03.XX

GR.01.0.01 (Internal part)

## ASSEMBLY INSTRUCTIONS

IMAGE 1

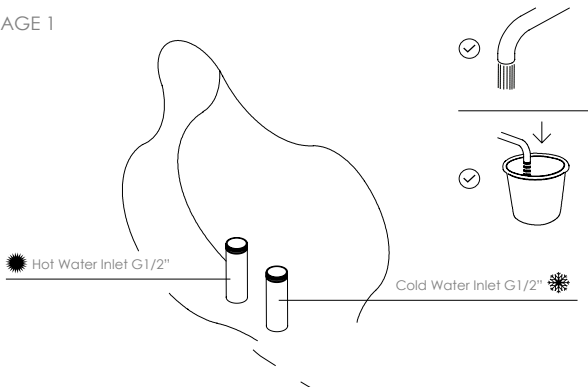

**Attention!** Before starting the installation, the pipes must be properly cleaned to eliminate any dirt that may cause permanent damages to the cartridge.

IMAGE 2

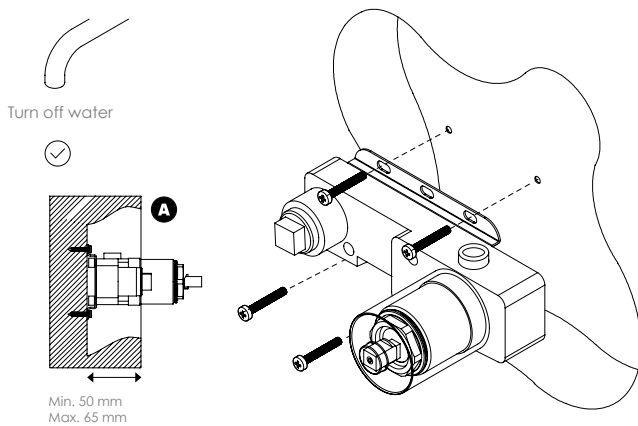

**Ensure the water supply is turned off before proceeding to the mixer installation.**

01 - Verify on the picture "A" the maximum and minimum measurements for internal part installation.  
Min. 50 mm / Max. 65 mm

02 - Please mark the wall where the internal part GR.01.0.01 will be placed.

03 - After marking four fixation points, drill the wall.

04 - Screw the fixing plate with compatible bolts (not included), leaving them untight enough for the following step.

IMAGE 3

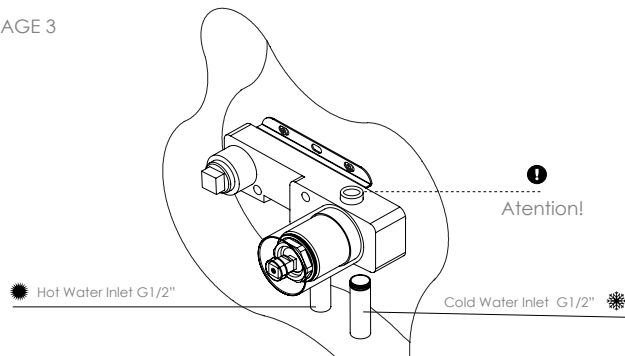

01 - Confirm on the spirit level (included on the mixer seat) that the piece is levelled with the floor (!). After ensuring the alignment is correct, conclude the tightening of the bolts.

02 - Proceed to the water connections, connecting cold and hot water to the corresponding tubes.

03 - Please guarantee that these connections are done correctly before placing the coating on the wall.

IMAGE 4

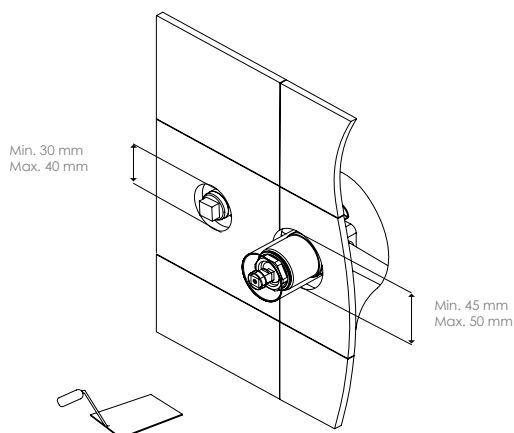

01 - Drill the holes on the coating, for the mixer and spout.  
Mixer diameter: Min. 45 mm / Max. 50 mm  
Spout diameter: Min. 30 mm / Max. 40 mm

02 - After completing step 1, proceed with the application of the coating.

## GR.01.2.03.XX

GR.01.0.01 (Internal part)

formma.

### CARTRIDGE REPLACEMENT

01

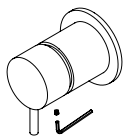

02

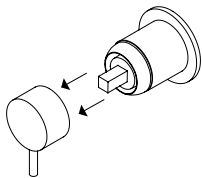

01 - Unscrew the handle with the help of the allen key.

02 - Remove the handle from the top of the cartridge.

03

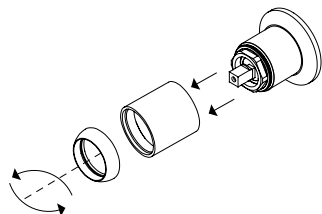

04

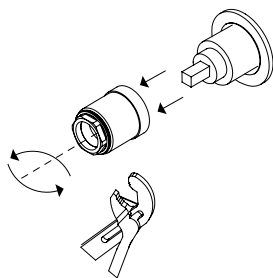

03 - Unscrew the cartridge concealer from the tecaform locknut, then remove the hood from the tecaform piece.

04 - Unscrew the tecaform locknut with the help of a wrench. After this, you can remove the cartridge.

Para instalar un cartucho nuevo, considere el procedimiento inverso.